

150th anniversary exhibition



Bahamas exam room, 1948

*Enriching the education of individuals
around the world*

150
YEARS
1858-2008

150 years of assessment

Cambridge Assessment was established as the University of Cambridge Local Examinations Syndicate (UCLES) in 1858. We were set up to administer local examinations for students who were not members of the University of Cambridge, with the aim of raising standards in education. Today, we develop and deliver examinations and tests in 150 countries.

150th anniversary exhibition

The Cambridge Assessment Archives Service holds a fascinating history of the development of our organisation and of educational assessment over the past 150 years. As well as holding a comprehensive set of question papers, regulations and examiners reports from the 1880s to date, our archives hold Syndicate papers, images and committee minutes. As the oldest UK surviving examination board, our archives provide a rich legacy that is continuing to grow for researchers now and in the future.

To commemorate our 150th anniversary in 2008, we have created an exhibition incorporating material from more than 40 items held by our archives service. Throughout the year, a collection of items from the exhibition will tour selected venues including our buildings in Cambridge and Coventry.

For further information

Further information can be found on the Cambridge Assessment website at www.cambridgeassessment.org.uk.

To see a copy of the full exhibition or to contact the Cambridge Assessment Archives Service please write to: The Group Archivist, Cambridge Assessment, 1 Hills Road, Cambridge, CB1 2EU, UK, or email: archives@cambridgeassessment.org.uk.



UNIVERSITY *of* CAMBRIDGE
Local Examinations Syndicate

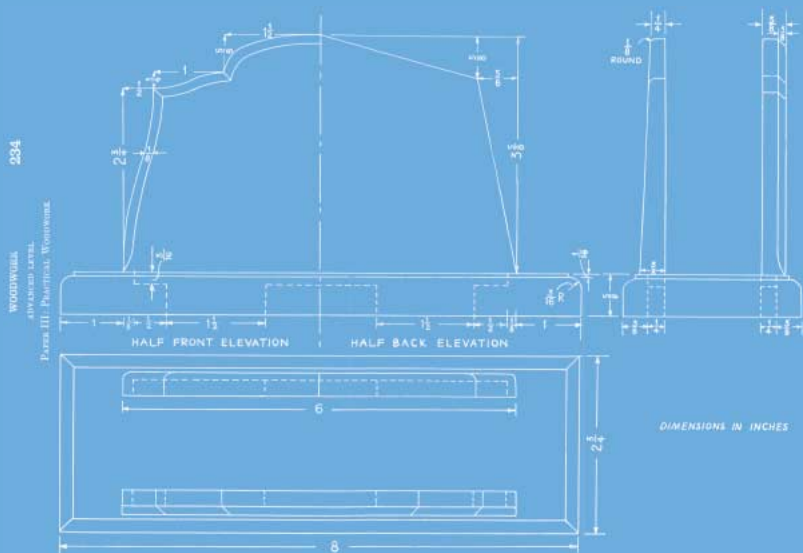

A level Woodwork examination, paper 3, practical, June 1956.

Fijian and Indian graduate students at the Teachers' Training college in Nainu, near Suva, Fiji, 1956. MP 1/6 iii

Describe the conditions in which the following are produced:

(a) Wool in the Union of South Africa

(b) Tobacco in Southern Rhodesia



Oversea School Certificate: Geography examination paper, part of question 13, December 1955.
Village school on the island of Moturiki, Fiji, 1956. MP 1/6 ii

It is said that the English love the sea. What effect has this had, in your opinion, on their way of life?



Certificate of Proficiency in English: English Life and Institutions paper, question 12, June 1956.
EFL candidates in an examination hall in Rome, June 1956. MP 1/3 iv

*How would you proceed to disinfect
a room that had been occupied by a
fever patient?*



Cambridge Senior Examinations: Physiology and Hygiene paper, question 1, July 1920.
Unidentified examination room c. 1910. MP 1/1

Premises



Single 'pendant' lighting design for UCLES'
Syndicate Buildings, Cambridge, 1893.

Archives A/PM 1/3

The continual expansion of the organisation has meant that many properties, in Cambridge and elsewhere in the UK, have been used as temporary offices. The Syndicate was given funding to have its own building and moved into 'Syndicate Buildings' in Mill Lane, Cambridge, where it remained until it moved to Hills Road, Cambridge, in 1965.

Today, Cambridge Assessment is Headquartered in Cambridge, with a major office in Coventry.

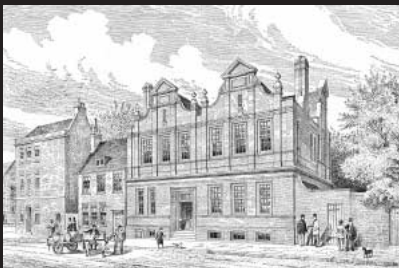

Syndicate Buildings, Mill Lane, Cambridge, 1886.
The Syndicate occupied this building until 1965.

Archives MP 5/2



The Syndicate Room, Syndicate Buildings, 1 Hills
Road, Cambridge, 1965. Archives MP 5/2

Cambridge Assessment

Cambridge Assessment was introduced in 1858 as the University of Cambridge Local Examinations Syndicate (UCLES).

UCLES amalgamated with the Local Lectures Syndicate in 1878 to form the 'University of Cambridge Local Examinations & Lectures Syndicate' which remained together until 1925.

From the mid 1980s, as successive governments in the UK moved to exert greater control over the school curriculum and examinations at ages 16 and 18, the number of English examination boards was reduced by a process of consolidation. During the 1990s UCLES merged with the Southern Universities Joint Board, the University of Oxford Delegacy of Local Examinations and the Oxford and Cambridge Schools Examining Board.

In 1998, UCLES created:

- ❖ An International Examinations division, now University of Cambridge International Examinations (CIE)
- ❖ Oxford Cambridge and RSA Examinations (OCR). OCR incorporates the first vocational assessment body in the UK – the Royal Society for the Arts, Manufacturing and the Sciences
- ❖ Cambridge EFL (English as a Foreign Language) which in 2002 became Cambridge ESOL (English for Speakers of Other Languages).

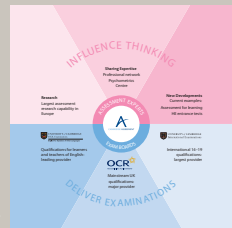

Group Chief Executive Simon Lebus, and Professor Alison Richard, Vice-Chancellor of the University of Cambridge, opened new offices at 9 Hills Road in 2005.

Recognising achievement

Assessment is the key to identifying and measuring achievement – it shows us when education works. Effective assessment enriches lives, broadens horizons and shapes futures.

The West Midlands Bursary Scheme, which is run by OCR, offers talented students an opportunity to win a bursary to the University of Cambridge.

Students from more than 30 countries wrote essays to celebrate the 20th birthday of the Cambridge International GCSE (IGCSE). The winner, Natalia Sánchez Thompson from Hastings School, Madrid, won educational vouchers worth £500 as well as a host of other prizes.

Cambridge Assessment has awarded a six-month secondment to a student from the University of Wales Institute in Cardiff (UWIC), as a result of the Futurelab Innovate to Educate Awards. James Cook won the placement for his project schools:united. The award was supported by Cambridge Assessment and the BBC.



Yasir Iqbal, Victoria Hendley, Mark Greatholder and Shabana Pervez – the first four winners of the West Midlands Bursary Scheme, 2004.

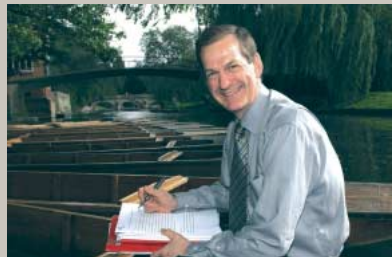

Mike Baker, BBC Education Correspondent, reads the winning essay on the River Cam, Cambridge in 2005.

Recent achievements

UCLES received a Queen's Award for Export Achievement in 1992.

To celebrate its new name in 2005, Cambridge Assessment hosted its first annual conference at Robinson College, Cambridge.

In December 2005, Cambridge Assessment's IM Customer Services Group was awarded a BS 15000 certificate in Information Technology – Service Management and a BS 7799 Information Security standard.

OCR and Cambridge ESOL operate a Quality Management System which complies with ISO 9001: 2000.

In 2006, Cambridge Assessment's research capability became the largest of its kind in Europe.



left: Top global education expert Baroness Onora O'Neill debates the key issue of trust in the UK assessment system at a conference held by Cambridge Assessment, 2005.

right: Chief Executive, John Reddaway, accepts a Queen's Award for Export Achievement on behalf of UCLES, 1992. Archives MP 4/2

Overseas exams



Celebrating 20 years of the Cambridge International GCSE (IGCSE), 2005.

UCLES' first overseas exam took place in 1864 in Trinidad. Today, the Syndicate is known as Cambridge Assessment, and it is one of the world's largest assessment agencies. It delivers examinations in 150 countries around the world.

The International GCSE (IGCSE) was developed in 1985. Today, the IGCSE is the most popular international qualification in the world.



Exam room in Bandung, Java, 1954. Archives MP 1/3 i



The West African Examinations Council was the first region to complete localisation. The WAEC offices in Lagos, Nigeria, in 1964. Archives MP 1/7



Cookery examination in Sarawak, Malaysia, 1956. Archives MP 1/6 i

REPORT OF THE SYNDICATE. *Feb. 7, 1865.*

The SEVENTH ANNUAL REPORT presented to the SENATE by the Syndicate appointed to conduct the Examination of Students not Members of the University.

THE Local Examinations held last December have been the most successful hitherto held, both as regards the number of Candidates, and the percentage of those who passed. They were held at the fifteen places in which they were held the previous year, and also at four new centres, namely, Barnstaple, Hastings, Southampton, Windsor. Moreover, an examination of 6 Senior Candidates was, by the courteous aid of the Colonial Office, successfully conducted in Trinidad.

The whole number of Candidates entered was 844; 665 Juniors, and 179 Seniors. This number of Juniors is 151 more than last year, about 30 per cent. increase. In the case of the Seniors, the increase is 64, or 35 per cent. Of the whole increase, 215, 72 are due to the four new centres; the chief part therefore arises from an increase at the old centres. All share in this increase with the exception of Bristol, where there is a slight decrease. The chief increase is at Exeter and Norwich, where it is about 80 per cent., and at Cambridge, Northampton, Plymouth, Sheffield, Wolverhampton, where the increase varies from 30 to 50 per cent. The decrease at Bristol is of no importance, as the number there last year was much larger than in 1862.

The following tables shew the general result of the Examinations as compared with former years. In each there is a column which gives an average free from the uncertainty of the first 2 or 3 years.

Wider introduction of examinations

The first UCLES exams took place on 14 December 1858, in eight UK regions: Birmingham, Brighton, Bristol, Cambridge, Grantham, Liverpool, London and Norwich. There were 370 candidates. Today, Cambridge Assessment despatches more than 20 million exam papers to 150 countries every year.

Cambridge Assessment is continually developing new assessments, the most recent of which include University Entrance Tests such as the BioMedical Admissions Test (BMAT) and uniTEST, and achieve, an interactive assessment for learning system.



UCLES sent a contribution to the 1900 Paris Exhibition to celebrate the turn of the century. The exhibition included this board detailing all UCLES centres worldwide. Archives M/PE 1

150 years, 150 countries

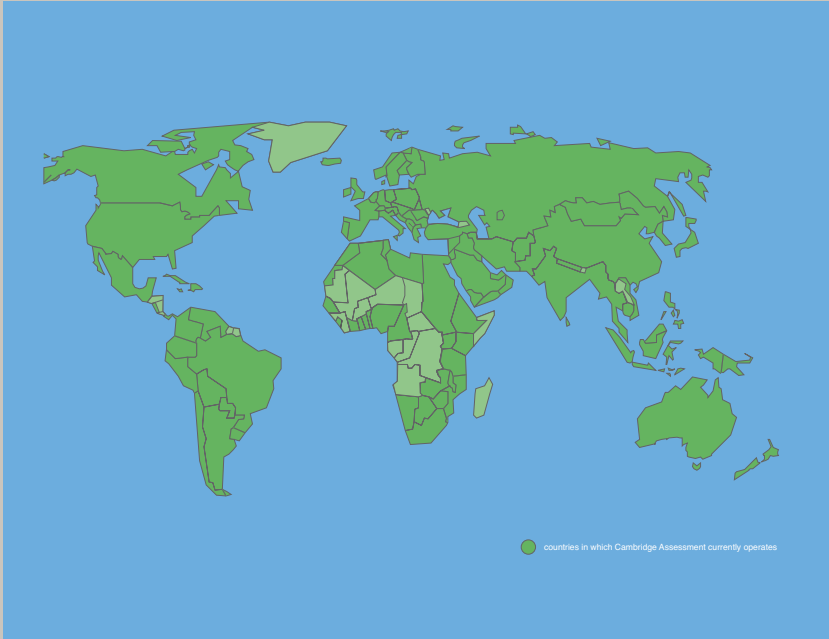

The earliest overseas centres were in Trinidad, Mauritius and Wellington, New Zealand, which were all established by 1877. Today, Cambridge Assessment sends out more than 20 million exam papers to over 150 countries around the world every year.



A CIE N level Awarding meeting at 1 Hills Road, Cambridge, in 2007. N level examinations are set specifically for candidates in Singapore.



Students of Chittagong Grammar School, Bangladesh, on their graduation day in Summer 2006. These students achieved excellent results in their CIE O Level exams.

Language testing

The first English as a Foreign Language examinations were for the Certificate of Proficiency in English (CPE), in December 1913. This was followed by the Lower Certificate in English and the Diploma in English Studies. The CPE is still taken today by candidates throughout the world.

Cambridge ESOL's work extends well beyond the provision of qualifications. It has major commitments to social integration and the encouragement of multilingualism, especially the Skills for Life and Asset programmes in the UK and its continuing work with the Association of Language Testers in Europe.

Today, Cambridge ESOL examinations are the world's leading range of certificates for learners of English, offering a range of qualifications for over two million candidates a year.

The Asset Languages programme is the assessment scheme for the Department for Children, Schools and Families Languages Ladder. The Asset Languages programme is being developed by Cambridge Assessment through its OCR and Cambridge ESOL exam boards, as part of the National Languages Strategy.



A group of Asset Languages students were presented with their certificates by UK Schools Minister Lord Adonis, December 2006.



Students at the EF International School of English, Cambridge, January 2007.

1858

The University of Cambridge set up a Local Examinations Syndicate in 1858. The examinations were administered from the College rooms of the Secretary of the Syndicate.

1864

UCLES has produced assessments worldwide since 1864. The first overseas exams took place in Trinidad.

One year later the first female candidates were accepted, for an initial trial period of three years.

1886

The Local Exams Syndicate moved into 'Syndicate Buildings' in Mill Lane, Cambridge.



Syndicate Buildings, Mill Lane, 1886.
Archives MP 5/2

1913

On the eve of the First World War, the first English as a Foreign Language Examinations were held in December; the Certificate of Proficiency in English still runs today.

1918

The School Certificate and Higher School Certificate were introduced as the first national school examinations. For UCLES these replaced the Cambridge Junior, Senior and Higher examinations for candidates in the UK.

1945

The Special Lower Certificate and Preliminary tests were taken by 1,500 prisoners of war in Great Britain alone.

The Awarding Committee assessed a batch of School Certificate examination scripts taken by British prisoners of war during the Second World War in a Singapore Internment camp.



Bahamas exam room, 1948. Archives MP 1/2

1951

General Certificate of Education (GCE) O levels and A levels were introduced in England.

They were primarily grammar school exams and replaced the School Certificate and the Higher School Certificate for UK examinations.

1964

The West African Examinations Council became the first region to complete localisation, a process of training by UCLES to enable regions to set their own examinations.



Office of the West African Examinations Council, Lagos, 1964. Archives MP 7/2

The following year UCLES moved to its current location, 1 Hills Road, Cambridge.

1988

The General Certificate in Education (GCSE) was introduced as a replacement for O level and CSE examinations. The international equivalent, the IGCSE was also examined for the first time.

1992

UCLES gained a Queen's Award for Export Achievement for the exportation of educational assessment services. The award was presented by the Lord Lieutenant of Cambridge.

1995

UCLES merged with the University of Oxford Delegacy of Local Examinations (UODLE) and the Oxford and Cambridge Schools Examination Board (OCSEB).

1998

UCLES created three exam boards: International Examinations, now known as University of Cambridge International Examinations (CIE); Oxford Cambridge and RSA Examinations (OCR) which incorporates the first vocational assessment body in the UK – the Royal Society for the Arts, Manufacturing and the Sciences; and Cambridge EFL (English as a Foreign Language) which in 2002 became Cambridge ESOL (English for Speakers of Other Languages).

2005

UCLES was rebranded as Cambridge Assessment for everything but legal issues. The new offices at 9 Hills Road, Cambridge, were opened by Professor Alison Richard, Vice-Chancellor of Cambridge University.



Farnborough Sixth Form College students sitting OCR IT Key Skills Level 2 exams using privacy filters, 2006.

2008

Cambridge Assessment celebrates 150 years with events, conferences and the publication of its first history: *Examining the World*.

UNIVERSITY OF CAMBRIDGE
LOCAL EXAMINATIONS SYNDICATE

Supervision at Approved Schools and other schools where the conduct of
the Syndicate's examinations is entrusted to the school staff

CERTIFICATE OF SUPERVISION

by the Principal and members of the staff at

St. James' Central School

DATE OF EXAMINATION *10-21st July '44* CENTRE NUMBER *173.*

CONDITIONS OF WORK DURING THE EXAMINATION

Please report here on disturbance, loss of sleep, etc., caused by air raids, and on any exceptional difficulties of individual School Certificate candidates during the examination period. N.B. Please attach a separate sheet for Higher School Certificate candidates, clearly marking it with the Centre number.

For a month candidates spent most of each day in the Shelter. These are used by public at night. By order of the Director of Education all Exams. were taken in the Shelter. The work of all candidates would suffer to some extent. There are three special cases: (1) 5224 External - Probationer, Nurse - Hospital furnished, helped with rescue work - nervous. (2) 5220 - Home bombed while she was at school. Fatal Casualties placed there. She saw them. Very nervous. Dying at a rest-centre.

(3) 5211 *St James'* Subject to Asthma. On the three

N.B. [This sheet must be returned to the Secretary, Syndicate Buildings, Cambridge, immediately on the close of the Examination.]

occasions when he went to the Shelter for his Maths. he had an attack. His work for the year was good and for the last term was well up to Credit standard. I feel he would reach this

The effects of war

During the First World War some scripts were lost when a ship was torpedoed off the Indian Coast and enemy shells disrupted examinations in the North East of England.

During the Second World War applications for special considerations like the one below documented the particular hardships endured by candidates in Britain. During both World Wars many staff left UCLES to join the forces and staff left behind sent comfort packets to troops.

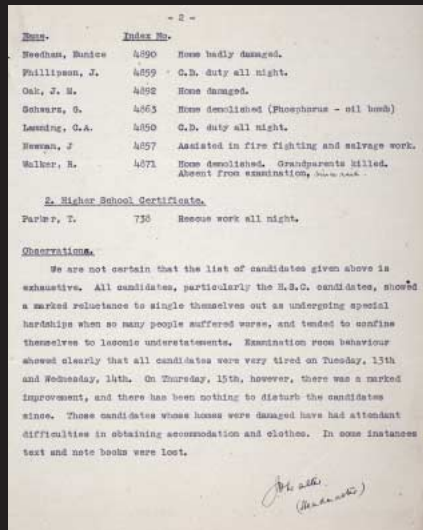
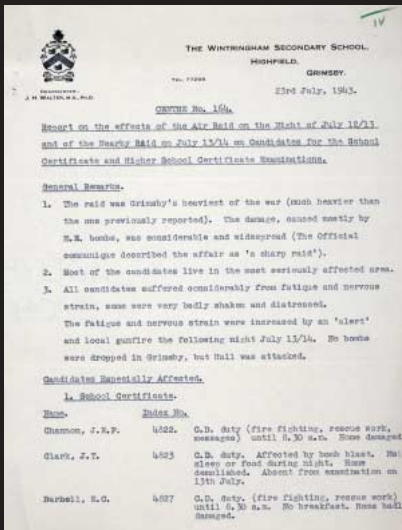

SPECIMEN

4

B

O

UNIVERSITY  OF CAMBRIDGE

LOCAL EXAMINATIONS SYNDICATE

SCHOOL CERTIFICATE

THIS IS TO CERTIFY THAT

passed the SCHOOL CERTIFICATE Examination *in January) 1945
August)

and reached the standards shown (Pass, Credit, or Very Good)

in the English Language test and in

the following subjects

* This was a special examination organised in the Singapore Internment Camp by representatives of the Malayan Education Department and later recognised by the University of Cambridge Local Examinations Syndicate.

Date of birth as stated
at time of entry

Grade Certificate
(see over)

Vice-Chancellor

Official visits to Europe

June and July 1937

and
October 1939

Note of
1974

In the summer of 1937 I had grace leave from the University and used part of it to 'expel' for my examinations in English in Europe.

The visit to Belgium in October 1939 had as an indirect result that the examinations were maintained clandestinely throughout the War.

My visit to Italy at Christmas 1939 had a similar result. The nuns at Florence kept a present for me hidden under the dais of a room used by German troops and Sister Pauline at Rome kept the examinations going throughout the War - without the name Cambridge.

The manuscript is in my hand. The typescript is my report to the Local Examinations Syndicate.

The frontpiece from J.O. Roach's travelogue from his tour of Europe, 1937. His post war annotation explains that he received secretly stored scripts during the war. Archives PP / JOR 2/4

Transcript:

My visit to Belgium in October 1939 had an indirect result that the examinations were continued clandestinely throughout the War. My visit to Italy at Christmas 1939 had a similar result. The nuns at Florence kept a present for me hidden under the dais of a room used by German troops and Sister Pauline at Rome kept the examinations going throughout the war - without the name 'Cambridge'.

Examiners

Thousands of examiners around the world mark Cambridge Assessment's exam scripts. With the advent of e-testing, exam papers could one day be a feature of the past.

"In Mathematics, the answers to the questions proposed shewed, in general, imperfect preparation on the part of the candidates."

UCLES Annual Report, 1859

"Most candidates had little scruple about writing down sheer nonsense."

UCLES Annual Report, 1921

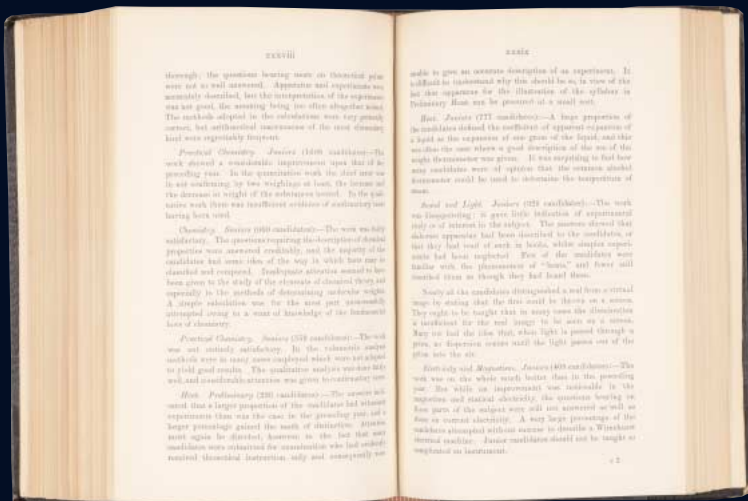

Miss Hind Howell complains that he did not as a rule wear cap & gown - She wd like a change of Examiner.

The book shows an extract from the Syndicate's report on the examinations of 1905, 48th Annual Report, 1906. The text underneath the book has been taken from a complaint about the Presiding Examiner sent by Norwich Girls' School, 1904. Archives A/EX / 1/1 p.139

University of Cambridge



This is to Certify that

Elizabeth Barnes

passed the Examination for JUNIOR Students held by the Syndicate appointed to conduct the Examination of Students not Members of the University.

Date of Examination, *December 1913* Index-number, *3257*

Age, *14* Centre, *Middlesbrough.*

The above-named Student satisfied the Examiners in the compulsory subjects, namely, DICTATION AND ARITHMETIC, and in the following sections or parts of sections:

- 1. Old Testament;*
- 2. English Composition and Literature;*
- 3. History and Geography;*
- 4. Algebra;*
- 5. Botany;*
- 6. Drawing (Freehand and Design).*

M. R. Jones VICE-CHANCELLOR.



Ramsey & Newport Studios

Standards setting for the Sudan School Certificate, 1955. Archives MP 1/4



Peter Adams

Marking work in the Craft Hall, 1 Hills Road, Cambridge, mid 1980s. Archives MP 5/8

170, Euston Road,
Morecambe,

Feb 6 1910

A. KERSHAW.

Dear Mr Keynes

My daughter Ethel sat for the
Senior Exam at Blackpool, and she was
so confident of passing because she thought
that she had managed everything so well, but
she has failed according to papers and I can
assure you she is heartbroken

Can it be possible do you think there has
been some mistake, I should be glad
if you could look the papers over again and
if it so happens there has been a mistake
so that you could send her a Certificate
I need not tell you there would ^{be} joy in
our home

I do not want to bribe you in any sense but
you shall be treated handsomely, yes I
would pray for you & Mrs Keynes a trip to
Paris. & be highly pleased to do so if you can
discover a mistake. Her No was 1540

In Confidence

Yours Sincerely
A. Kershaw

UNIVERSITY OF CAMBRIDGE
LOCAL EXAMINATIONS SYNDICATE



GENERAL
CERTIFICATE OF EDUCATION

This is to certify that in the Examination for the General
Certificate of Education held in 1951 (Summer)

passed at the levels indicated (Advanced or Ordinary) in
the subjects shown below:

Index number

S.C. Roberts

Vice-Chancellor

THE MINISTRY OF EDUCATION accept the examination as
reaching the approved standard.

Signed on behalf of the Ministry of Education

R.N. Heaton

Under-Secretary

Transcribed from manuscript
of H.R. Beck, 1873

Clarendon House
Hale Road

June 19th /73

My dear Papa and Mamma

I arrived here this morning from Rugby, all my troubles over. Aunt and the little ones are quite well, uncle home, and Bob in Scotland.

I am feeling very tired and utterly worn out with excitement and nervousness. My exam was even more difficult than I had anticipated, the Divinity especially. On Monday I had five hours of that, right off with only a cup of coffee in the middle. We met about 15 in a large room and each had a seat prepared with name and No, paper, pen, ink.

A Fellow of Cambridge, cap-a-pie, like Mr Johns, very severe looking, sat at the head of the room, or walked up and down, and frightened me out of my little wits. On Monday, I went home feeling that I must give it all up, and take to scrubbing floors for a livelihood. If Mr and Mrs Warner had not been so kind, I do not know that I should have done. They hid away all my books, and made me laugh and talk all the evening, or rather talked to me, and abused Devonshire till I was rather belligerent.

On Tuesday, the mathematical paper, Arith and algebra, was from nine to eleven, only 2 hours for 20 long sums. Too bad! I did 15, and went home, settled myself in an armchair, and had a fit of hysterics. I never felt like it in my life, though I was very quiet about it. There was another paper (History) at four. I couldn't eat any lunch, but had a cup of coffee and unlimited sal volatile and eau de Cologne.

I went to the Examination Room, feeling certain I should be obliged to give up at once, but the paper was a most lucky one, I knew every question, they were on the very parts I had freshest in my memory. There were 38 questions, and I answered the whole, no other candidate answered more than 35, many not 20. Wasn't it nice? In the evening there was a large party at the Warner's, mostly masters and their wives and daughters, many of the last being candidates for the Exam.

On Wednesday we had Literature and Language at nine a.m. till eleven. Rather a stiff affair, but I got through it without feeling any more nerves. At four, there was Eng. Composition, which, of course, I couldn't do. The Head Master of Rugby School had invited all the candidates to a croquet party at his house so having dressed in best bib and tucker, Mrs Warner and I went over. I felt very nervous about my pass, as you may think, for I wasn't certain one sum was right, and my Scrip[tur]e Hist[ory], was bad. However I played a game of croquet with the Examiner as a partner, and found out he was much like other people.

I was speaking about my fears of passing, and the time it would be before I should know, and what do you think he said "I have looked over your papers, and I don't mind saying in strict confidence that you have every chance of taking a first". Allowing everything for his wish to make me comfortable, I think I may feel pretty sure of getting somewhere in the dim background after that. I lost the game of croquet, of course - I always do.